



SRE-2010 Electra-Ride Elite™ Stairway Elevator
Technical Specifications

rev: 06-01-2009
ILS-00826

MODEL NUMBER: SRE-2010 & SRE-2010C
U.S. F.D.A. CLASSIFICATION: Class II,
CLASSIFICATION NUMBER: 890.5150

PERFORMANCE STANDARDS: USA Food & Drug Administration: None
ANSI/ASME: A18.1-2005 Safety Standards for Platform Lifts and Stairway Chairlifts
ANSI/ASME: A17.1-2004 Commercial (PART XX) &
Private Residence Inclined Lifts (PART XXI)
CSA C-US Listed: File Number 208135

RATED LOAD: 400 lbs maximum

NUMBER OF PASSENGERS: 1

POWER SOURCE: 24 Volt DC comprised of 2ea 7amp/hr 12 volt sealed maintenance-free lead acid batteries. On/Off power switch to prevent battery drain over lengthy storage periods.

CHARGER: 110 Volt AC 1.5 Amp, 24 Volt DC 2 Amp continuous monitoring, full primary cut off.

DRIVE: 24 Volt DC direct drive gear-motor, 2 pole rated .68 HP, 58:1 right angle self-locking worm gear box, 41.5 RPM on the output shaft of the gear box.

FINAL DRIVE: Integrated 8dp gear rack on rail with a spur gear on the gearbox output shaft.

MOTOR CONTROLLER: Custom 24 Volt DC PWM controller with acceleration ramping.

BRAKING: dynamic motor braking through the motor controller, self locking worm gear box, and electro-mechanical motor brake.

REMOTE CONTROL: Infra-red wireless "CALL/SEND" control. Momentary switching
Requires a user to continuously hold button to control unit.

Bruno Independent Living Aids, Inc., 1780 Executive Drive, P.O. Box 84, Oconomowoc, WI 53066
Phone (800) 882-8183 Fax (262) 953-5501

Any reproduction or other use of these materials without written permission of Bruno Independent Living Aids, Inc. is expressly prohibited. Bruno Independent Living Aids, Inc. reserves the right to modify or make changes to these specifications at any time without notice.

STANDARD CONTROL: 3 position, momentary rocker switch requiring user to continuously hold rocker switch to control unit, switch mounted under armrest. Optional keyed control.

MOUNT: Either side of stairway, the unit is easily installed on either side of the staircase.

SUPPORTS: Clamps anchored to stair tread, normal rail position is 2" above step nose. Number of clamps dependent on the length of rail. Optional height adjustable clamps available.

ANGLE: Adjustable from 0 to 45 degrees standard, specials to 50 degrees.

SPEED: Maximum top speed is 25 feet per minute. Actual speed will vary depending on rider weight

LENGTH OF TRACK: 16 foot & 20 foot standard, Dealer to cut to fit the actual length of the stair, see application guide. Custom lengths available.

TRACK CONSTRUCTION: Aluminum extruded rail with covered steel gear rack. Bolted joint plate at each rail connection.

OPTIONAL FOLDING TRACK: Optional rail with manually actuated hinge system to fold rail away from restricted access ways at the lower landing of the staircase.

FOOTREST: Folding footrest with safety sensor panel and handle actuator.

SEAT: Padded, Folding & Swiveling with stops at 45 (bottom), 0 (forward), 60 (top), and 90 (top). Multiple position seat height adjustments.

ARMRESTS: Fixed to seat frame. Armrest can be individually rotated towards seat back for smaller profile when not in use and easier transfers. Armrests have 4" width adjustment

SAFETY EQUIPMENT: 1) Seat swivel switch allows operation only when chair is in center Position.
2) Carriage & Footrest safety switches
3) Retractable seat belt
4) Charging light (green) on carriage
Charging light (amber) at each end of rail
5) 30 amp manual reset breaker on the motor control circuit
6) 5 amp fuse on the control circuits
7) Final end stop bumper at each end of the rail
8) Final limit switch
9) Full diagnostic interconnect circuit board
10) Optional overspeed safety brake

POWER OUTAGE: Unit will have 8 (minimum) to 20 round trips on battery charge (variance caused by angle, length of run, ambient temperature and rider weight). Batteries will last between 28 and 36 hours after the power is disconnected.

WEIGHT OF UNIT: 300 lbs. without rider in a typical 16 foot installation

**Bruno Independent Living Aids, Inc., 1780 Executive Drive, P.O. Box 84, Oconomowoc, WI 53066
Phone (800) 882-8183 Fax (262) 953-5501**

Any reproduction or other use of these materials without written permission of Bruno Independent Living Aids, Inc. is expressly prohibited. Bruno Independent Living Aids, Inc. reserves the right to modify or make changes to these specifications at any time without notice.

TESTING PERFORMED:

- 1) Life cycle testing with full rated load at 45 degrees on a 16' rail in process.
- 2) Battery charger meets UL 1236 battery charger specifications and has been Independently tested.
- 3) The self locking gear box was statically tested with 3200 lbs (8X rated load) on a 45 degree rail for 5 minutes with no carriage movement. This test was performed at the manufacturer's location.
- 4) Repetitive tests were run to determine power outage cycling.
- 5) Electrical discharge to ground testing performed for FDA 510(k).

OPTIONS:

1. Keyed remote call/send controls,
2. Keyed Controls on chair arm,
3. Commercial package w/overspeed safety brake
4. Power swivel seat at top landing up to 90 degrees of rotation
5. Power footrest actuated off of seat storage position

**Bruno Independent Living Aids, Inc., 1780 Executive Drive, P.O. Box 84, Oconomowoc, WI 53066
Phone (800) 882-8183 Fax (262) 953-5501**

Any reproduction or other use of these materials without written permission of Bruno Independent Living Aids, Inc. is expressly prohibited. Bruno Independent Living Aids, Inc. reserves the right to modify or make changes to these specifications at any time without notice.

TECHNICAL DATA/SPECIFICATION

MODEL: SRE-2010 ELECTRA-RIDE ELITE
 RATED LOAD: 400 LBS, ONE PASSENGER
 POWER SOURCE: 24 VOLT DC COMPRISED OF (2) 7 AMP/HR
 12 VOLT SEALED BATTERIES
 110 VOLT AC 1.5 AMP, 24 VOLT DC 2 AMP
 CONTINUOUS MONITORING CHARGER.

DRIVE: 24 VOLT DC DIRECT DRIVE GEAR-MOTOR, 2 POLE
 RATED .68 HP, 58:1 RIGHT ANGLE SELF LOCKING
 GEARBOX, 41.5 RPM NO LOAD RPM OUTPUT SPEED.
 SUSPENSION: RACK & PINION - INTEGRATED 8DP GEAR RACK
 ON RAIL WITH A SPUR GEAR ON THE OUTPUT
 SHAFT OF THE GEAR BOX.

BRAKING: DYNAMIC MOTOR BRAKING THROUGH THE MOTOR
 CONTROLLER, SELF LOCKING WORM GEAR, AND
 ELECTRO-MECHANICAL MOTOR BRAKE.

CONTROLS: CONTINUOUS PRESSURE ROCKER SWITCH LOCATED
 ON THE ARM REST AND WALL MOUNTED CALL/SEND
 CONTROLS LOCATED AT BOTH THE TOP AND BOTTOM
 LANDINGS.

ANGLES: 0 TO 45 DEGREES (SPECIALS UP TO 50 DEGREES) RIGHT
 OR LEFT HAND ORIENTATIONS.

FINAL LIMIT SWITCH STANDARD
 OPTIONS:

- 1) KEYED CALL/SEND CONTROLS,
- 2) KEYED CONTROL ON CHAIR,
- 3) COMMERCIAL PACKAGE W/OVERSPEED SAFETY BRAKE.

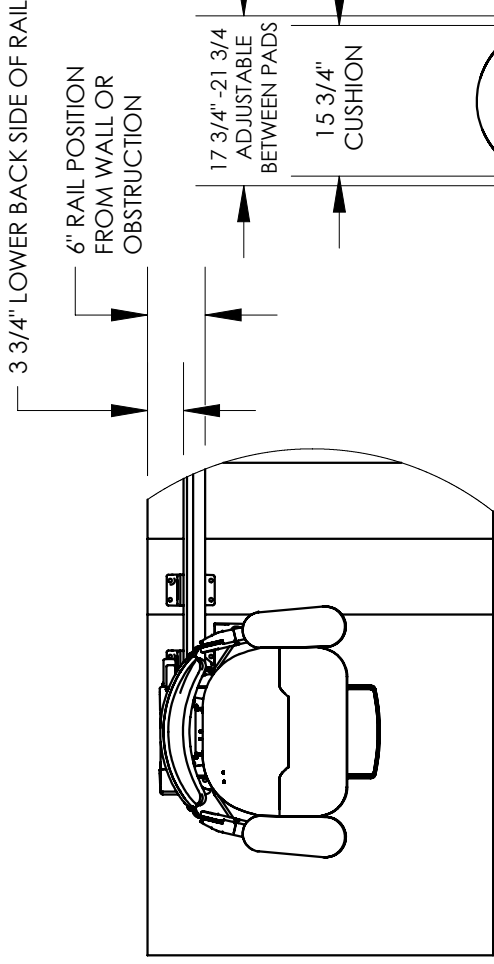

TOP VIEW

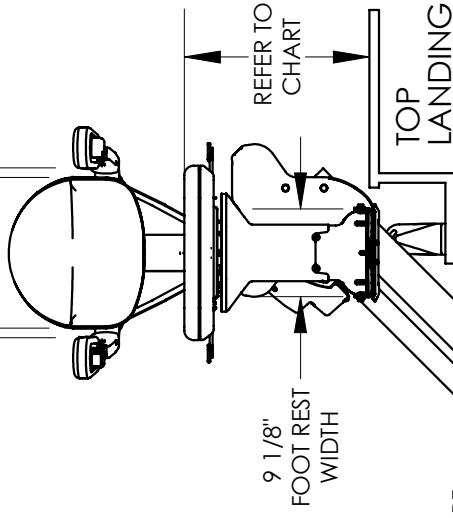

ELEVATION VIEW

LOWER LANDING EXTENSION DIMENSIONS ARE
 BASED ON 45 DEGREE RAIL SLOPE ON AN
 8" 1ST RISER HEIGHT, DIMENSIONS WILL VARY
 BASED ON SLOPE AND RISER HEIGHT.

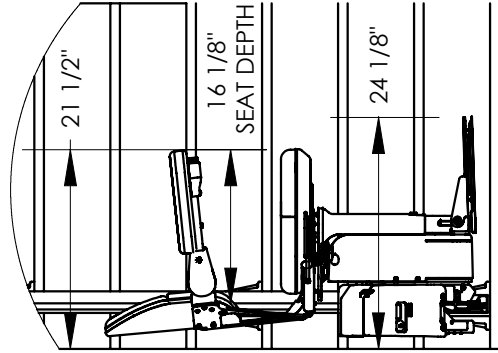
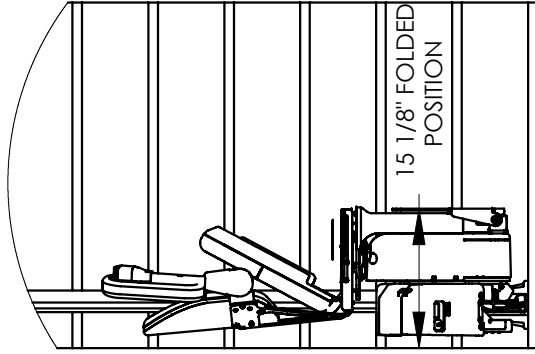
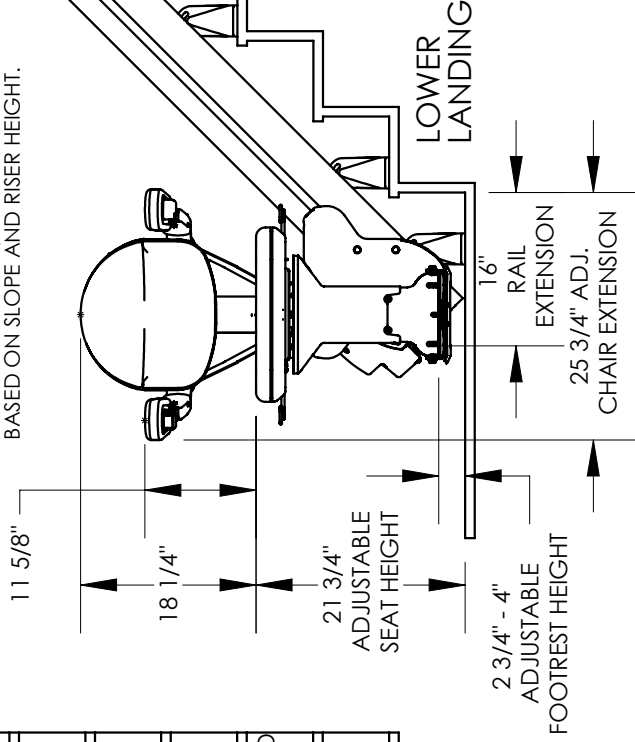

SIDE VIEWS

1780 Executive Drive
 P.O. 84
 Oconomowoc, WI 53066
 Tel 800-882-8181
 Fax 262-953-5501
 www.bruno.com



©2009 Bruno Independent Living Aids, Inc.

ILS-00827
SHEET 1 OF 2
REV. 06-02-09

SRE-2010 FOLDING RAIL

AUXILIARY
ELEVATION VIEW
RAIL FOLDED
DOWN POSITION

AUXILIARY
ELEVATION VIEW
RAIL FOLDED
UP POSITION

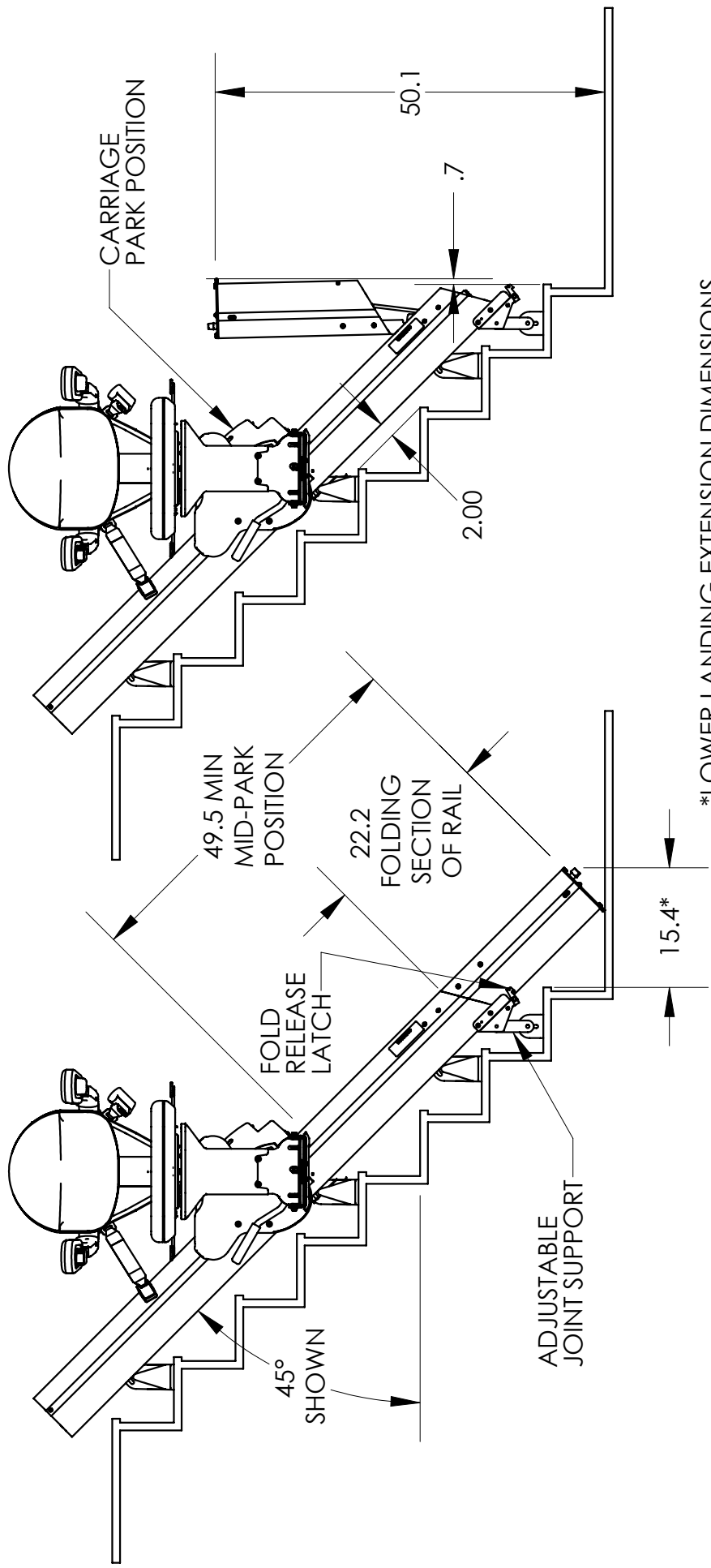

*LOWER LANDING EXTENSION DIMENSIONS ARE BASED ON 45° RAIL SLOPE AND 8" RISER HEIGHT. DIMENSIONS WILL VARY BASED ON SLOPE AND RISER HEIGHT.

SRE-2010 POWER OPTIONS TYPICAL DRAWING

SUPPLEMENTAL SEAT AND FOOTREST DIMENSION FOR POWER OPTIONS

CARRIAGE AND SEAT ELEVATION VIEW
SEAT AND FOOTREST SHOWN IN LOWEST POSITIONS
FOR RIGHT HAND INSTALLATIONS

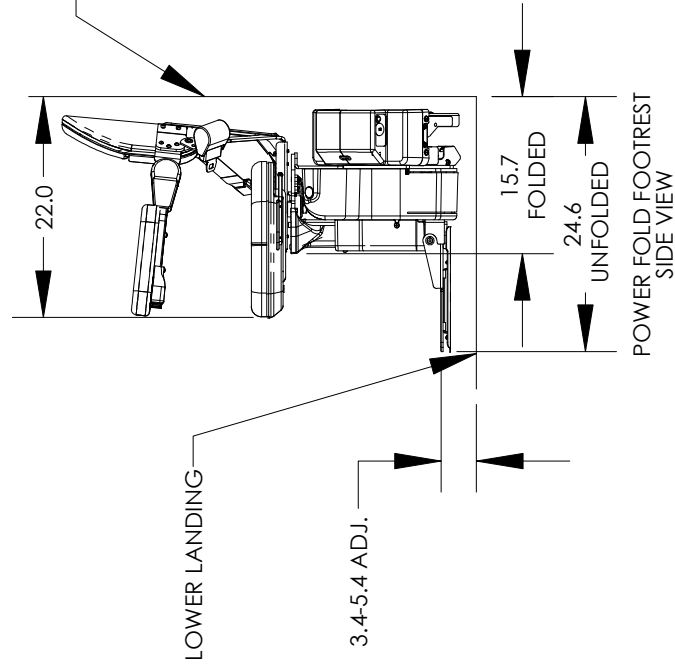
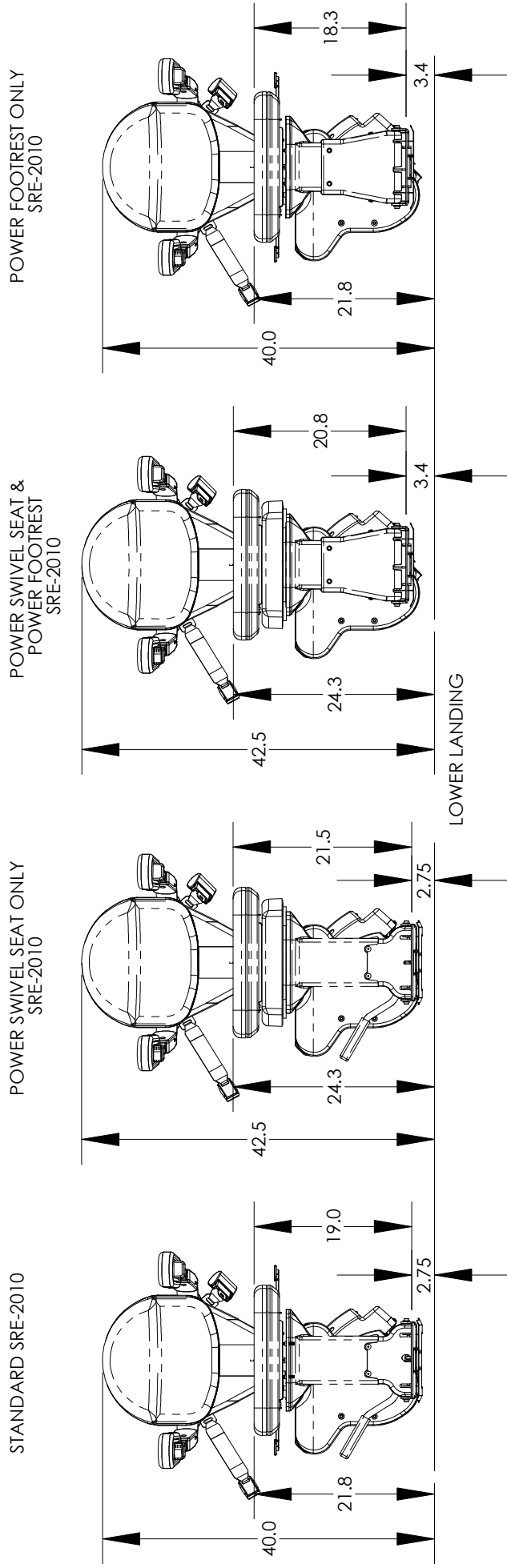

NOTES:

- 1) ALL SEATS ADJUST UP 3" IN 1" INCREMENTS
- 2) STANDARD FOOTREST ADJUST UP 1 1/4" IN 5/8" INCREMENTS
- 3) POWER FOOTREST ADJUST UP 2" IN 1" INCREMENTS

ILS-00853
SHEET 1 OF 1
REV. 0 (0)(12-11-08)(T.O'B)